

Tunability – An Enabling Technology for Wireless

INTRODUCTION

Wireless communication equipment used in cellular, wireless LAN, GPS, radar and other technologies, makes use of a number of tuned RF (radio frequency) circuits. Tuned circuits play an important role in determining the overall signal quality, sensitivity, size and power consumption of mobile wireless devices and the base stations that serve them. In the sense used here, “tuned circuit” refers to an analog circuit such as a filter and may also be called an LC (“L” for inductor, “C” for capacitor) or resonant circuit. Tuned circuits are designed to respond optimally when functioning at a specific frequency, power level or impedance. However, the mobility provided by wireless communications insures that these conditions do not remain constant but vary considerably with location. Knowing that this variability is in store, the equipment designer often designs for nominal operating conditions and lives with sub-optimum performance when other conditions prevail. Or, the designer may make use of several components in a parallel configuration, switching between them as conditions change. In many cases, a better solution is the use of a single circuit that is not only tuned, but tunable. Tunable circuits can be adjusted, or re-tuned with a simple voltage adjustment to function optimally as conditions change. Depending on the specific circuit where such tunability is used, the result may be a savings in cost, reduction in size, improved battery life, better performance, or increased manufacturability. This paper will provide further detail on why this is so.

The Effectiveness of Wireless Networking

Wireless is proving to be an increasingly convenient, cost effective means of connectivity on several different scales. Mobile phones are everywhere, providing wide area networking (WAN) over a range of kilometers. Providing connections up to a hundred meters or so, wireless local area networks (WLAN's) are gaining rapid acceptance in business and home networking. Wireless Personal area networks (WPAN's) enable wireless communication over a few meters, essentially serving as cable replacements, and are increasing in popularity as technologies mature. Likewise, the advantages provided by wireless communications are not lost on the military community. Using a virtual armor based on wireless

detection and deterrence measures, future combat systems will be able to decrease dependence on physical armor. It will respond to threats quickly and accurately through the use of a system of interconnected wireless networks on the battlefield.

A PROLIFERATION OF STANDARDS

Each of these types of wireless networks has a set of technical challenges that differ from the others. Most often, more than one standard has been developed to meet each challenge. For example, there are a large number of cell phone standards based on GSM (Global System for Mobile Communications) and CDMA (Code Division Multiple Access), and there are a number of different implementations within each one. Adding further complexity, different countries have allocated different frequency ranges for use with these standards.

In the area of WLAN the situation is marginally less complex. There exist three competing IEEE standards called 802.11a, 802.11b, and 802.11g that are known as “Wi-Fi”, in addition to the HiperLAN, OpenAir and HomeRF standards. For WPAN's there are also various IEEE 802.15 standards and Bluetooth. In the military, a variety of legacy communications systems exist and newer, more elaborate ones are under development.

WIRELESS DESIGN CHALLENGES

Despite this proliferation of standards and frequencies, it is highly desirable for a mobile device to roam seamlessly across geographic boundaries, accommodating different protocols and frequencies of use as required. It may also be desirable that it be able to communicate in WPAN, WLAN and WAN modes of operation. At the same time, the consumer demands that all this added functionality not come at the expense of size, cost or battery life. A number of such devices are beginning to appear on the market in the form of tri-band or quad-band handhelds that incorporate multiple cellular modes as well as Bluetooth or Wi-Fi functionality. This generally implies that the designer use a number of circuits that are duplicated for each band, with the

Tunability – An Enabling Technology for Wireless Systems

associated penalties of increased size, weight and cost. In contrast, a tunable circuit can perform the function of two or more parallel circuits with a simple change in control voltage. Figure 1 illustrates this situation for the case of duplexers in a tri-band system.

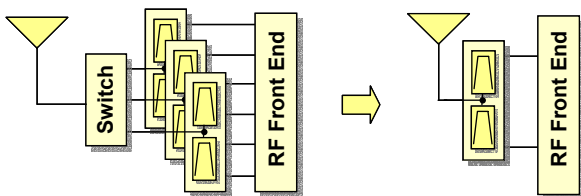

Figure 1: In a tri-band system, a single tunable duplexer can replace three fixed duplexers

Amplifiers

Frequency is not the only variable that may change as the user roams within a service area. In some wireless systems, the mobile device must adjust its output power downward as the user gets closer to the base station. This is done to assure that the base station receives the same power level from all users within its reach and the signal from the nearby user does not drown out the weaker signals from more distant users.

As an amplifier's power is adjusted away from its maximum output, there is also a resultant change in its impedance, a property that affects how efficiently power is transferred out of the amplifier. When the impedance is not properly matched, power is reflected backwards and wasted. Circuits called matching networks are designed specifically to improve the impedance related power transfer, but fixed matching networks can only provide optimum power transfer at one power level. Without concurrent adjustment of the matching circuitry, the efficiency of the amplifier decreases and battery power is wasted. A tunable matching circuit is able to adjust for the changing impedance of the amplifier and insure maximum power transfer under all conditions, improving battery life. The use of an RF component called an isolator between the power amplifier and the antenna was common practice until recently. The isolator helped alleviate the mismatch situation between the power amp and the antenna, but its use has been largely discontinued due to the severe size constraints that exist for these products. The result is that the matching circuit in this part of the device has taken on even more importance.

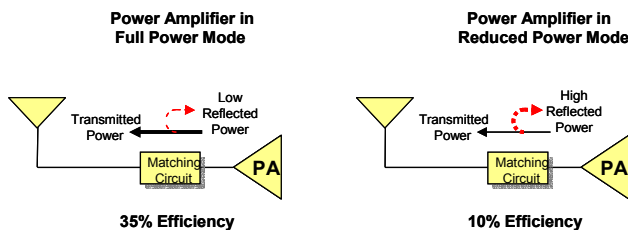

Figure 2: An amplifier without a tunable matching circuit becomes less efficient in reduced power mode because of impedance changes that are not compensated by the matching network.

Antennas

Wireless systems use antennas to radiate power from the transmitter circuitry into the air (they also receive signals from the air and direct them into the receiver). Like amplifiers, antennas have impedances that affect how efficiently they can transfer power into the air. The antenna's impedance is altered by the external environment surrounding it and therefore its power transfer efficiency is affected as the user moves. The effect can be quite drastic, changing the antenna's impedance several-fold. During periods when the external environment causes poor power transfer, the amplifier may be called upon to make this up by producing more power, resulting in reduced battery life. In systems where the amplifier power is fixed, the result is reduced range. Again, when tunability is employed in the antenna's matching circuitry, power transfer and resulting battery life or signal quality can be significantly increased.

End of Line Tuning

The precision RF circuitry used in wireless communications generally requires a large number of discrete passive components. Passive components include resistors, capacitors and inductors and exclude such active devices as transistors, diodes or integrated circuits. Recent examples of complex, multi-band phones have in excess of five hundred such passive devices. Each of these components has a manufacturing tolerance associated with it that can cause the circuit response to differ from the required response. For example, a filter may be designed from ten or more passive components, each with

Tunability – An Enabling Technology for Wireless Systems

its own manufacturing tolerance; a capacitor specified at 10 picofarads (pF) +/-10% may arrive from the manufacturer at 11 picofarads. The result of all the component deviations is that the filter response may not be centered at the proper frequency, causing some unwanted signals to be admitted and some desired signals to be rejected. A common solution to this problem is to tune precision RF circuits at the end of the production line, a process sometimes called phasing. Tuning, or phasing, is a process where a technician makes a circuit adjustment until a test instrument indicates the circuit's response has been optimized. The adjustment may be a screw turn or the physical removal of material, sometimes by sophisticated laser trimming techniques. With a tunable circuit, this could be accomplished with a simple voltage adjustment potentially not even requiring human intervention, reducing cost and time in the manufacturing process.

How Tunable Circuits Work

Tunable circuits from Agile Materials & Technologies, Inc. are based on capacitors that use a ferroelectric material called Barium Strontium Titanate (BST) as the dielectric material. The dielectric constant of BST, and therefore capacitance value, can be adjusted by applying a DC voltage. When the value of a capacitor in a circuit is changed, the impedance and phase relationships in the circuit are affected in predictable ways. These parameter changes can be exploited to yield tunable impedance matching networks, tunable filters, phase shifters, and other functions where a variable capacitor, or varactor, is used. Figure 3 shows the capacitance tuning curve for a BST capacitor. For this capacitor, the zero voltage capacitance is about 32 pF, but when a voltage of plus or minus 4 volts is applied, the capacitance decreases by about one half, to about 16 pF. When used as an element in a resonant circuit, a reduction in capacitance by one half corresponds to a resonant frequency shift of 42% and similarly a 3:1 capacitance change corresponds to a frequency shift of over 70%. An important point to remember is that the capacitor draws no current other than its very small leakage current, and therefore the power dissipation in the control circuit is virtually negligible.

Phase shifters are a straightforward application of variable capacitance. As pointed out earlier, when capacitance changes, the phase response of the circuit is affected. Phase is, of course, the critical parameter to be varied in a phase shifter. Phase shifters have

important applications in base stations and are a critical device in the functioning of phased array antennas. Phased array antennas are expected to increase the efficiency of wireless systems by allowing signals to be radiated only in the direction required, instead of sending it out in all directions as is commonly done now.

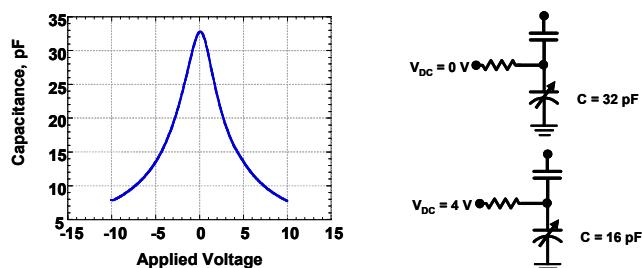

Figure 3: (Left) Tuning curve for a BST capacitor. (Right) how a DC voltage is applied to the capacitors, resulting in a capacitance change.

Agile Materials & Technologies, Inc. produces tunable circuits in fully integrated form. The BST-based capacitors are produced along with resistors, inductors and other capacitors to form an integrated passive circuit on a single substrate. This is accomplished using standard thin film processing and results in passive circuits that are much smaller than corresponding circuits made from discrete passives that are surface mounted on the printed circuit board. The combination of tunability and passive integration will provide a double advantage to designers in size and cost reduction.

The Future of Tunable Circuits

Tunable circuits may be retrofitted into existing designs where some element of voltage control is readily available. For example, when the amplifier of a handheld device is made to reduce its power output, the same control signal used for the amplifier can potentially be used to adjust the tunable matching network. Reductions in size, weight and cost, and improved performance and battery life will result.

More applications can be found for tunable circuits if the architecture of the equipment is planned to accommodate them. When the tuning voltages

Tunability – An Enabling Technology for Wireless Systems

and control logic for tunable circuits are built into the architecture, full advantage can be taken of the continuous tuning characteristic of the circuits.

As a further evolutionary step, fully adaptable circuits can be designed, where a feedback loop is employed as shown in Figure 4. The resulting devices will be able to automatically respond to changing operating conditions, continuously optimizing its response. In the example of Figure 4, power is sampled from the forward direction, and the control circuit's function is to apply the proper control voltage to the matching network such that forward power output is continuously maximized. Such circuits would not only be able to self-asses and self-optimize for changing operating conditions such as power level, impedance and frequency, but would also compensate for the effects of temperature and aging.

CONCLUSIONS

Wireless systems designer are faced with challenges from all directions. The communications systems they develop must provide a reliable channel of ever increasing bandwidth within strict frequency limits that can vary from region to region. Since the wireless channel is uncontrolled, the operating conditions for mobile devices are subject to continuous change. Meanwhile, the consumer demands that battery life, talk time, size, weight and cost of the equipment remain reasonable. Tunable circuits of the type described here can help bring these apparently mutually exclusive requirements within reach. Tunable technology can be leveraged advantageously into present designs, and in the longer term have the ability to enable a new class of agile, adaptive circuits that will help propel wireless communications into the future.

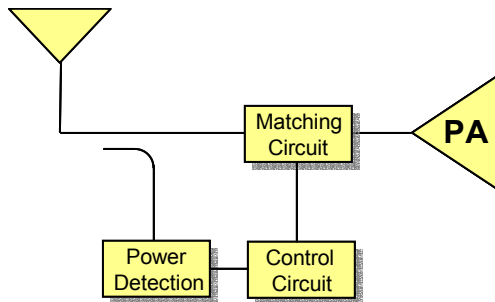

Figure 4: Conceptual diagram of a self-adjusting matching network